

MARINE



WASTE WATER TREATMENT
VACUUM CONVEYING
WASTE HANDLING



ELKUCH GROUP



“We understand the requirements of our customers”

QUALITATIVELY SUPERIOR SYSTEMS FOR MARITIME APPLICATIONS

As an internationally operating company, ELKUCH supports its customers with complete onboard systems for maritime applications. ELKUCH stands for quality and reliability in maritime plant engineering and puts its focus on space-saving system designs. Our project managers support you throughout the entire process lifecycle: from pre-planning, during the construction and building phase through to commissioning.

APPLICATIONS

- Mechanical pre-treatment units
- Grey water treatment
- DAF
- Membrane filtration systems
- Waste handling systems
- Vacuum conveying systems
- Exhaust air treatment
- Tank equipment
- Remote services and maintenance

TYPICAL ARRANGEMENT FOR BLACK AND GREY WATER TREATMENT

Wastewater from the vessels usually consists of a grey and black water stream characterized by high loads of COD, BOD5, fats, solids, nitrogen and phosphorus. Elkuch has developed a special concept which is a combination of a high-efficient pre-treatment solution for the grey water stream backed by a sufficient biomass reactor to treat both streams in a final step with a guaranteed superb effluent quality at all time. Our systems are tailored to the requirements of our customers and certified to meet IMO MEPC 227 (64).

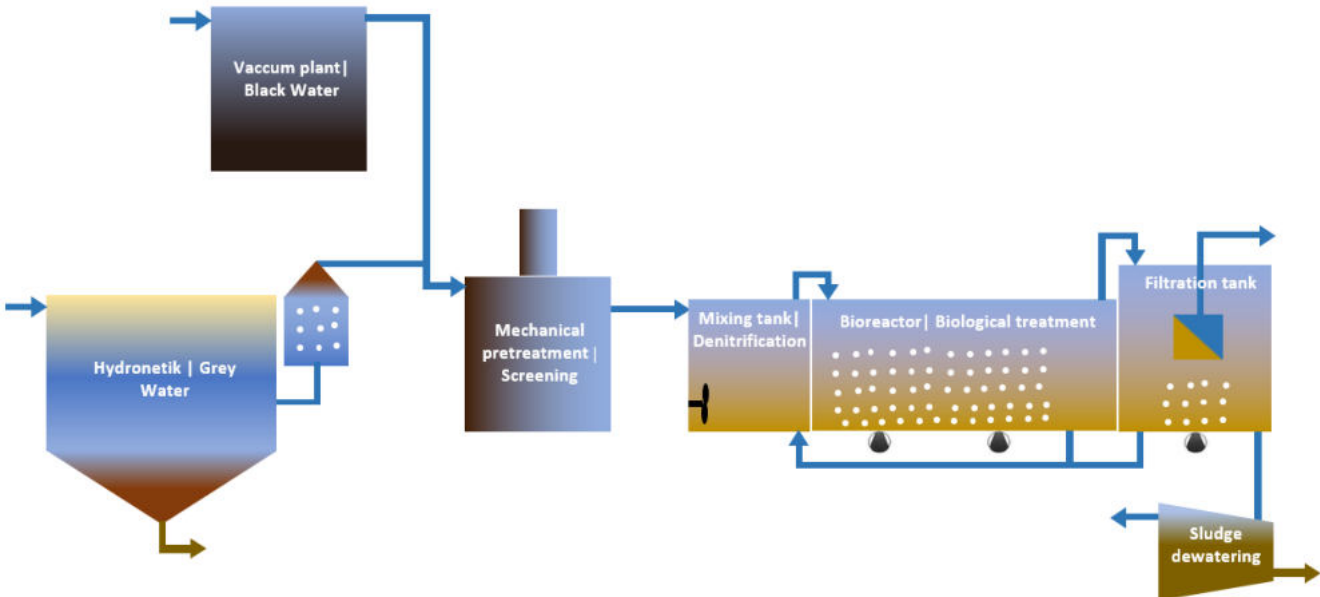



Design
Support
Engineering
Production
Assembly
Maintenance

WASTE WATER TREATMENT TECHNOLOGIES FOR VESSELS

MECHANICAL PRETREATMENT - SCREENING

Our solid-liquid separators used for applications where liquid media circulate in open or closed systems and must be separated from solid foreign matter. Separation of the solids is done by a filter mesh which is transporting the screenings and enabling a thickening process within the fully enclosed system.

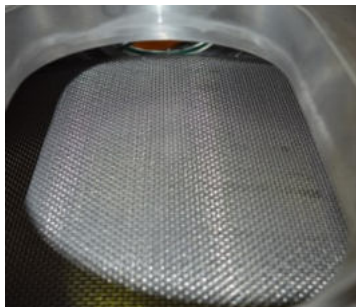

COMPACT MEMBRANE BIOREACTOR

Membrane bioreactor processes combine the biological treatment stage with a downstream filtration unit, making a conventional secondary clarifier obsolete. In the activated sludge stage, bacteria first break down the organic pollutants and constituents of the mechanically pre-treated wastewater under aerobic conditions and convert them into biomass. In the downstream ultrafiltration stage, high-quality ultrafiltration membranes with a pore size $< 0.1 \mu\text{m}$ separate the clear water fraction from the activated sludge.

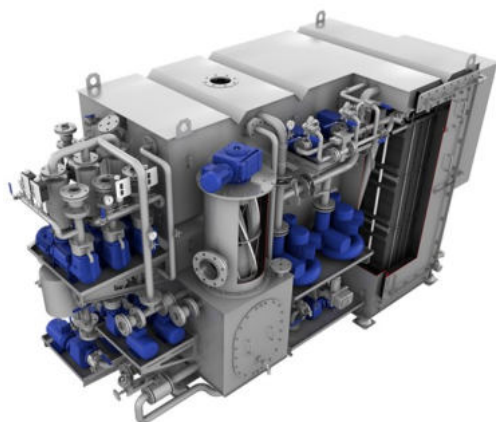

HYDRONETIK – DISSOLVED AIR FLOTATION

Impressively efficient, is our 3-stage process where the grey wastewater is fed directly into the holding tank. The newly integrated dissolved air flotation system draws emulsions and suspended solids into the high-efficiency separator, where microbubbles clean the wastewater. The disturbing substances for the downstream MBR plant are thus removed and minimize the fouling of the membrane.



SLUDGE DEWATERING

With our sewage sludge disintegration, the excess sludge can be dewatered. In addition, stabilizing and degrading processes lead to further minimization of sewage sludge.





VACUUM CONVEYING & WASTE HANDLING

SHOCK TESTED VACUUM CONVEYING UNITS, DESIGNED FOR MILITARY VESSELS

Since the 1990s, Elkuch has designed and manufactured a variety of vacuum conveying systems. Vacuum conveying units collect sewage, condensation, and food waste by pumping it into a collection tank and macerates it for the discharge process. Particularly suitable for vessels from medium to high crew capacities, the tanks are fitted with a pneumatic mixing mechanism to prevent sedimentation and a level-sensor system to prevent slurry overflow. Discharge is remote controlled via the main automation system.



MOBILE DOCKING - INLET STATION

The docking station is used to dispose of food leftovers from the kitchen in the waste tank. The food scraps are fed to the mobile containers with a capacity of 50 liters. The lever lock couples the roll container with the suction device. The suction process is started. The docking station can optionally be equipped with an automatic cleaning system. The process is carried fully automatically and includes the complete emptying and internal cleaning of the roll container.

WASTE HANDLING EQUIPMENT

We manage mixed or recyclable waste in a way that is safe, convenient, environmentally friendly and energy efficient, reducing the volume and space through compaction and shredding. Our range includes:



Glass crushers



Compactors

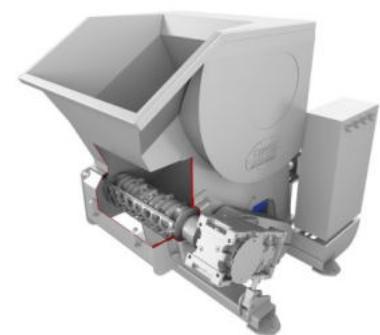

Shredders



REFERENCES

TESTED AND CERTIFIED SOLUTIONS

Our current naval portfolio includes selected equipment designed and tested to the latest and most stringent military requirements including; Shock, EMC, Noise and Vibration, Magnetic Permeability and Fire Resistance. Our range of references includes: Navy Vessels, Super Yachts, Cruise Vessels and Explorer Vessels



EGV



F124 / F125 / F126



K130



Gorch Fock



Planet



Al Mirqab



Waste Solutions

Contact Waste Solutions

Headquarters

Ludwig Elkuch AG
Schaanerstrasse 35
9487 Bendorf
Liechtenstein
+423 375 84 00
office@elkuch.com

Sales

Sales Elkuch Waste Solutions
Cioffo Arturo
+423 375 84 63
wastesolutions@elkuch.ch

For more information visit us on www.elkuch.com



ELKUCH GROUP